

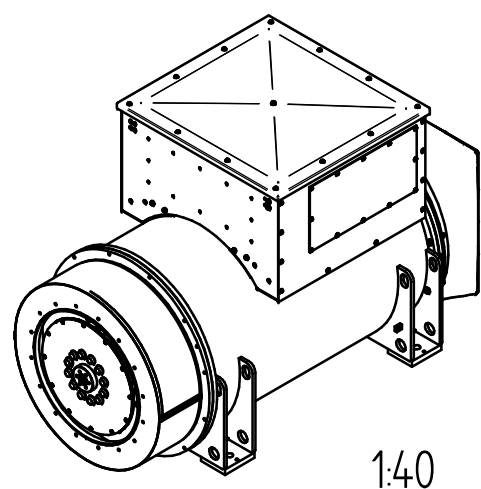

Supplied by Leroy Somer
 4 jacking screws HM27x2-100
 2 dowell pins A16-120

Values on page 2/2

Articles usinés : Tolérances ISO 2768-mH & rugosité générale : Ra 3.2		Articles bruts: Tolérances ISO 2768-ch		Ce plan est la propriété de la société MOTEURS LEROY SOMER et ne peut être communiqué sans son autorisation	
G	.	.	.	Projet :	3300V to 13800V Single bearing
F	.	.	.	N°:	.
E	.	.	.	Divers:	P1 542 1001
D	.	.	.	Machine:	LSA 54.2 /4P
C	.	.	.	Désignation:	Main Dimensions Encombrement
B	.	.	.		
A	First issue/1ère création	G.C	21.11.2014		
Rev	Description	Nom	Date		
	Dessiné: G.Chauvette	le: 21.11.2014		 ORLEANS-FRANCE Page 1 / 2 Voir échelle sous la vue	A3 EN 542 1001
	Verifié: Q.GAUTIER	le: 21.11.2014			
	Visa: .	le: .			
	Méth: .	le: .			
					Rév A

Voltage	Type	A (mm)	B (mm)	C (mm)	Stator length (mm)	D (mm)	E (mm)	XG (mm)	Weight (kg)
3300 V	VL7	857	1180	1400	1700	2507	1835	1101	6900
	VL9	857	1180	1400	1700	2507	1835	1146	7350
	XL11	1057	1380	1600	1900	2707	2035	1201	8100
	XL13	1057	1380	1600	1900	2707	2035	1241	8450
4160 V	VL7	857	1180	1400	1700	2507	1835	1101	6900
	VL9	857	1180	1400	1700	2507	1835	1146	7350
6300 V	VL7	857	1180	1400	1700	2507	1835	1101	6850
	VL9	857	1180	1400	1700	2507	1835	1146	7300
	XL11	1057	1380	1600	1900	2707	2035	1201	8100
	XL13	1057	1380	1600	1900	2707	2035	1241	8450
10500 V	XL7	1057	1380	1600	1900	2707	2035	1151	6950
	XL9	1057	1380	1600	1900	2707	2035	1201	7400
	XL11	1057	1380	1600	1900	2707	2035	1231	7700
	ZL12	1157	1480	1700	2000	2807	2135	1271	8200
	ZL14	1157	1480	1700	2000	2807	2135	1311	8650
13800 V	UL5	957	1280	1500	1800	2607	1935	1191	6300



Articles usinés : Tolérances ISO 2768-mH & rugosité générale : Ra 3.2		Articles bruts: Tolérances ISO 2768-ch		Ce plan est la propriété de la société MOTEURS LEROY SOMER et ne peut être communiqué sans son autorisation	
G	.	.	.	Projet :	3300V to 13800V Single bearing
F	.	.	.	N°:	.
E	.	.	.	Divers:	P1 542 1001
D	.	.	.	Machine:	LSA 54.2 /4P
C	.	.	.	Désignation:	Main Dimensions Encombrement
B	.	.	.		
A	First issue/1ère création	G.C	21.11.2014		
Rev	Description	Nom	Date		
	Dessiné: G.Chauvette	le: 21.11.2014		 ORLEANS-FRANCE	Page 2 / 2 Voir échelle sous la vue
	Verifié: Q.GAUTIER	le: 21.11.2014			
	Visa: .	le: .			
	Méth: .	le: .			
				A3	EN 542 1001
					Rév A